

## EVALUATION RESULTS OF NUSANTARA 5 AUTONOMOUS UNDERWATER VEHICLE (N5-AUV) IN A CONTROLLED ENVIRONMENT AND THE OPEN SEA

### HASIL EVALUASI NUSANTARA 5 *AUTONOMOUS UNDERWATER VEHICLE* (N5-AUV) DI LINGKUNGAN TERKONTROL DAN LAUT TERBUKA

Muhammad Rafly Amanullah Fahmi, Indra Jaya\*, Muhammad Iqbal

Study Program of Marine Science and Technology, Faculty of Fisheries and Marine Sciences, IPB University, Jl. Agatis, IPB Dramaga Campus, Bogor 16680, Indonesia

\*Corresponding author: [indrajaya@apps.ipb.ac.id](mailto:indrajaya@apps.ipb.ac.id)

(Received June 2, 2024; Revised November 25, 2024; Accepted April 7, 2025)

#### ABSTRACT

An Autonomous Underwater Vehicle (AUV) is a vehicle operated underwater using a propulsion system, controlled and navigated by a computer system, and capable of maneuvering in three dimensions. It is designed to perform tasks underwater that are difficult for humans to accomplish. This research aims to document the design and development of the Nusantara 5 AUV made by the MITR Club of Marine Science and Technology, Faculty of Fisheries and Marine Sciences, IPB University, as well as to evaluate its performance both in field conditions and controlled environments. The evaluation method for the vehicle involved comparing the movement results in water with the programmed motions of straight movement, turning, and gliding. The performance testing results indicated that the AUV could move straight with an average error of  $2.8^\circ$  in a controlled environment, while in the sea, the average error reached  $5.4^\circ$  because the AUV was tossed around by the sea waves. During turning maneuvers in controlled conditions, the AUV required 12.8 seconds to adjust its path after turning, whereas in the sea, it took 20 seconds. Gliding motion was still not perfect, both in the test pool and in the sea, as it tended to move up and down. This indicated a weakness in the Nusantara 5 AUV itself. However, the advantage of the Nusantara 5 AUV itself was in its smaller size compared to its predecessors and the use of fewer thrusters, thus minimizing manufacturing costs.

Keywords: autonomous underwater vehicle, design, performance testing

#### ABSTRAK

*Autonomous Underwater Vehicle* (AUV) adalah wahana yang dikendalikan di dalam air menggunakan sistem penggerak, dikontrol dan dikemudikan (dikendalikan) oleh perangkat komputer, dan bermanuver pada tiga dimensi. AUV memiliki kegunaan untuk melakukan pekerjaan di bawah air yang sulit dilakukan oleh manusia. Penelitian ini bertujuan untuk mendokumentasikan desain dan pembuatan Nusantara 5 AUV yang dikembangkan oleh MITR club ITK (Ilmu dan Teknologi Kelautan), FPIK (Fakultas Perikanan dan Ilmu Kelautan), IPB University dan mengevaluasi kinerjanya baik di lingkungan lapangan maupun dalam kondisi terkontrol. Metode evaluasi wahana menggunakan perbandingan hasil gerakan di air dengan program gerakan lurus, berbelok, dan *gliding*. Hasil pengujian kinerja menunjukkan bahwa AUV mampu bergerak lurus dengan rata-rata kesalahan sebesar  $2,8^\circ$  dalam lingkungan terkontrol, sedangkan di laut, rata-rata kesalahannya mencapai  $5,4^\circ$  dikarenakan AUV terombang ambing oleh ombak laut. Saat melakukan manuver berbelok dalam kondisi terkontrol, AUV memerlukan waktu 12,8 detik untuk menyesuaikan jalurnya setelah berbelok, sementara di laut, waktu yang dibutuhkan adalah 20 detik. Gerakan *gliding* masih belum sempurna, baik di dalam kolam uji maupun di laut, karena cenderung bergerak naik turun. Hal ini mengindikasikan sebuah kelemahan dalam Nusantara 5 AUV itu sendiri. Walaupun demikian, kelebihan dari Nusantara 5 AUV sendiri adalah ukurannya yang lebih kecil dibandingkan dengan pendahulunya dan juga penggunaan jumlah *thruster* yang lebih sedikit sehingga dapat meminimalisir biaya pembuatan.

Kata kunci: *autonomous underwater vehicle*, rancang bangun, uji kinerja

## INTRODUCTION

An Autonomous Underwater Vehicle (AUV) is a vehicle that operates underwater using a propulsion system, controlled and navigated by a computer, and maneuvers in three dimensions (Ngatini and Nurhadi 2019). AUVs are useful for performing tasks that are difficult for divers due to depth limitations and are life-threatening. Many methods used to identify sediments in coastal areas can damage ecosystems and destroy coral reefs, but using AUVs can be a solution for identifying benthic conditions in coastal waters. AUVs for port security tasks, including environmental inspections, surveillance, and mine detection (Widiharto *et al.* 2022). Additionally, AUVs can be used for inspecting cracks and damage in underwater structures (Jacobi 2015) and tracking and locating ore, oil, and natural gas reserves (Sahoo *et al.* 2019).

The Nusantara 5 Autonomous Underwater Vehicle (N5-AUV) is the successor to the previously developed Nusantara 3 AUV (Ratnasari *et al.* 2020). The N5-AUV has a more compact design and fewer thrusters while maintaining the maneuverability of its predecessor. The general specifications of the N5-AUV include a length of 575 mm, 433 mm in width, 267 mm in height, a weight of 11 kg, and materials made of polyethylene and acrylic. The N5-AUV has a bullet- or torpedo-shaped hull, a design commonly found in underwater vehicles. For example, the first AUV ever built, SPURV, also had a torpedo-like shape. Other AUVs with similar designs include those developed by Shome *et al.* (2012), Hiller *et al.* (2012), Hyakudome (2011), 'STARFISH' by Hong *et al.* (2010), 'Maya' by Desa *et al.* (2007), 'SPARUS II' by Carreras *et al.* (2018), and 'MARTA' by Allotta *et al.* (2016). The N5-AUV operates at 14.8V with a 5200 mAh battery, providing 4 hours and 17 minutes of runtime at 1213.6 mA power consumption. However, it falls short compared to the TifTu AUV, which can dive to 350 meters depth, features GPS and USBL tracking, and runs for 8–10 hours on a 3.5 kWh battery supplying 350 W (Allotta *et al.* 2016). Therefore, further development of the N5-AUV is needed to make it a more reliable vehicle for underwater exploration. This research aims to document the design and construction of the Nusantara 5 AUV, developed by the MITR Club of the Department of Marine Sciences and Technology, Faculty of Fisheries and Marine Science, IPB University, and to test its

maneuverability in both controlled and real-world environments.

## METHODS

The development of the AUV was carried out from November 2020 to September 2021, with optimization and refinement for sea trials conducted from February to July 2023 at the Marine Instrumentation and Robotics Laboratory of the Department of Marine Science and Technology, IPB University, and the IPB Aquatic Sport Center Pool. The sea trials were carried out on July 18-22, 2023, at the Hall of Sea Farming IPB University, Pulau Semak Daun, Seribu Islands, Jakarta.

The tools and materials used in this research include both hardware and software. The software included a laptop, Visual Studio Code, Python, and Google SketchUp. The hardware consisted of a power drill, screwdriver, soldering iron, digital multimeter, electric grinder, and lathe machine. The construction of the Nusantara 5 AUV required several key components, including a Logitech C270 HD 720p webcam, a Bar 30 high-resolution pressure sensor (depth of 300 m), an Arduino Mega microcontroller, a Raspberry Pi 4, six 30A ESCs, and a CMPS14 sensor. Additionally, it utilized two 30A UBECs, six T300 thrusters, two 5200 mAh 4S batteries, and a DOM camera casing. The structural components included three polyethylene sheets, one acrylic tube, 60 nuts, bolts, and screws, as well as two aluminum rods (20 mm diameter, 1 m length). Assembly was completed using six units of Araldite adhesive.

The Nusantara 5 AUV was powered by a 14.8V Li-Po battery with a 5200 mAh capacity. To estimate its operational endurance, the following formula was used:

$$D = \frac{Cb \text{ (mAh)}}{Am \text{ (mA)}}$$

Where D is battery endurance in hours, Cb is battery capacity in mAh, and Am is current electric consumption in mA. Based on these calculations, the N5-AUV has an estimated operational endurance of approximately 4 hours and 17 minutes.

The instrument design is a complex process that requires integration of three key design aspects, such as mechanical construction, electronic construction, and software design. Therefore, in this research,

an integrated approach was applied to ensure seamless coordination between these three processes. Several stages in the instrument design process were systematically arranged into a flowchart, outlining the research workflow. The detailed research flow can be seen in Figure 1.

#### *Platform design*

The construction of the AUV frame involves the use of polyethylene, following a pre-designed model created using SketchUp, as shown in Figure 2. This frame serves as a key structural component that provides strength and stability to the AUV. In addition to frame construction, a specialized tube was also developed to function as the pressure hull. This tube is also made from polyethylene and is precisely shaped to fit the acrylic tube, which forms an integral part of the AUV. These two elements work together to create a strong and pressure-resistant structure, which is crucial for ensuring the internal components remain protected in the underwater environment.

#### *Hardware design*

The Nusantara 5 AUV is equipped with high-quality electronic components, including Arduino Mega, Raspberry Pi, CMPS 14, Blue Robotics Electronic Speed Controller (ESC), Thruster T200, and the MS5837 depth sensor to enhance its performance. The Blue Robotics ESC and T200 thrusters serve as the primary propulsion system, ensuring smooth and stable movement in water. The CMPS 14 sensor is used to determine the AUV's heading by digitally utilizing the Earth's magnetic field in real-time. Meanwhile, the MS5837 sensor monitors water pressure changes at varying depths, also in real-time. The CMPS 14 sensor is connected to the Raspberry Pi, while the MS5837 sensor is linked to the Arduino Mega. Both sensors are critical components that allow the AUV's control system to make movement decisions based on real-time data. To meet its power requirements, the AUV uses a 14.8V 4S Li-Po battery. Acrylic is used as the base for mounting and organizing the electronic components. Details on power consumption for each component can be found in Table 1, while images of the electronic components are shown in Figure 3.

#### *Software design*

The AUV programming is implemented using the Python programming language on the Raspberry Pi. The Raspberry Pi functions as the central processing unit of the system, managing various aspects of the AUV. It processes the sensor data received from different sensors and interprets it in real-time, allowing the AUV to make decisions based on its surrounding environment. Meanwhile, the Arduino Mega is responsible for reading depth sensor data and controlling the thrusters. As a thruster microcontroller, it regulates the thruster speed, ensuring precise maneuverability underwater.

The Raspberry Pi and Arduino Mega communicate through a serial data connection, which facilitates the transmission of commands and sensor data between the two devices. This serial communication is essential for ensuring that the AUV operates smoothly, with synchronized movement and real-time response to environmental changes. The overall program flow is depicted in Figure 4.

## **RESULTS AND DISCUSSION**

### **Design**

#### *Platform*

In the mechanical aspect, the process of constructing the frame and pressure of the hull tube focuses on essential structural elements in the design of the Nusantara 5 Autonomous Underwater Vehicle (N5-AUV). The construction of the AUV frame follows a design created in the SketchUp application. Polyethylene is cut using a jigsaw and assembled with stainless steel screws, ensuring resistance to seawater corrosion. Stainless steel contains a minimum alloy composition of 18% chromium and 8% nickel, forming a protective oxide layer on the surface of the metal, which prevents rust from damaging screws or other components (Sinaga *et al.* 2020). The frame is elongated to enhance the AUV's stability in the water. According to Hakim (2014), the design characteristics influencing stability include the aspect ratio between the vehicle's total length and width, as well as the placement of the thrusters, which significantly impacts overall stability.

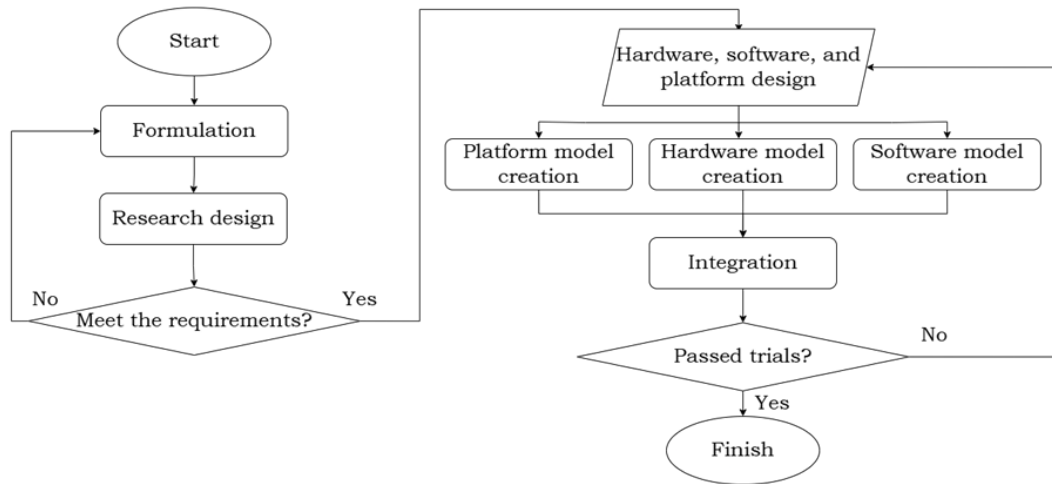

Figure 1. Research method flowchart on the evaluation results of Nusantara 5 autonomous underwater vehicle (N5-AUV) in a controlled environment and the open ocean.

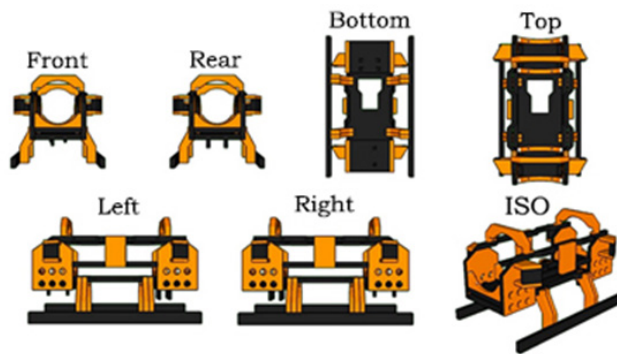

Figure 2. AUV frame design using SketchUp.

Table 1. Power consumption of each electronic component in the AUV.

No	Component	Volume	Current (mA)
1	Raspberry pi 4	1	600
2	Arduino Mega	1	75
3	T200 Thruster	6	50
4	CMPS 14	1	18
5	MS5837	1	0.6
6	Logitech C270	1	220
<b>Total</b>			1.213,6

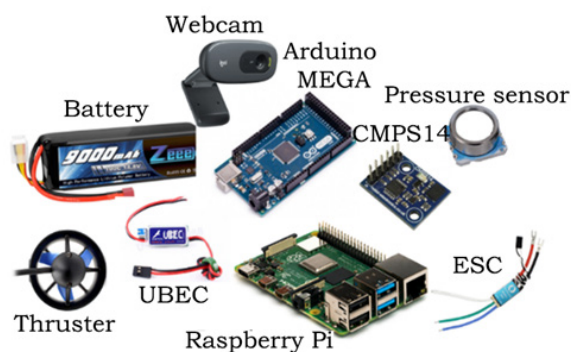

Figure 3. Electronic components used in AUVs.

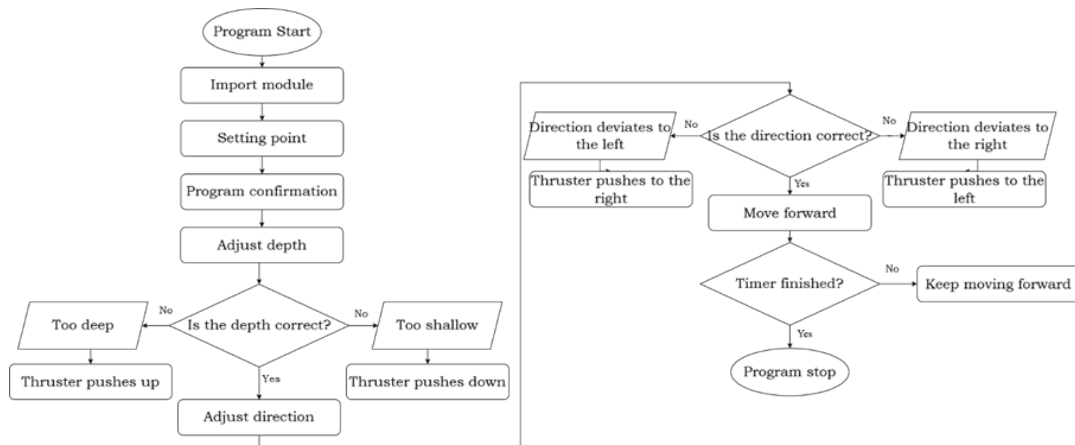

Figure 4. Program workflow in the AUV to determine the path.

Both sides of the frame are equipped with propulsion motors, commonly called thrusters. These thrusters serve to propel the AUV and control its movement in the water, including vertical motion. While the frame shape resembles that of Nusantara 3, Nusantara 5 is considerably smaller. In addition, Nusantara 5 is equipped with six thrusters, compared to the eight thrusters used in Nusantara 3 (Ratnasari *et al.* 2020). This reduction in thrusters was implemented to optimize costs without compromising movement quality. As shown in Figure 5, thrusters numbered 1 to 4 are positioned at the front and rear of the AUV to enable forward, backward, and turning movements. These thrusters are angled to facilitate maneuverability. Meanwhile, thrusters numbered 5 and 6, located in the middle of the AUV, are responsible for vertical movement, allowing the AUV to ascend and descend.

A cylindrical pressure hull with a dome at the front was chosen due to its streamlined design and availability on the market. Waterproofing is achieved using polyethylene on both ends, as shown in Figure 6. This shape resembles a round-head skirt bullet, which has a low drag coefficient of 0.4313 (Sugita and Dzaky 2017). According to Sugita and Dzaky (2017), the more streamlined an object is, the lower its drag coefficient, whereas larger cross-sectional areas result in higher resistance. The pressure hull tube is mounted on the upper part of the frame, as illustrated in Figure 5.

### Hardware

The Autonomous Underwater Vehicle (AUV) is built using an Arduino Mega as the controller for the Electronic Speed Controller (ESC) and the MS5837 sensor, which is responsible for depth measurement. The power and data flow diagram is presented in Figure 6, where the Raspberry Pi functions as the central processing unit of the system. It handles visual data from the camera and compass readings, and runs the primary program. The Raspberry Pi is powered by a 14.8 V lithium-ion battery, with voltage regulation down to 5 V using a UBEC. Meanwhile, the Arduino Mega is powered via a USB cable directly connected to the Raspberry Pi. Serial communication is established between the Raspberry Pi and the Arduino Mega, allowing real-time data exchange. The Raspberry Pi processes underwater conditions and relays the information to the Arduino. Then it adjusts the thruster speeds accordingly to adapt to real-time environmental changes.

The thrusters are mounted outside the AUV using a penetrator to connect them to the external environment beyond the pressure hull. In addition to the thrusters, the MS5837 sensor also needs to interact with water. Therefore, a penetrator is also used to establish its connection with the underwater environment. The placement of the penetrators on the AUV's cover can be seen in Figure 7.

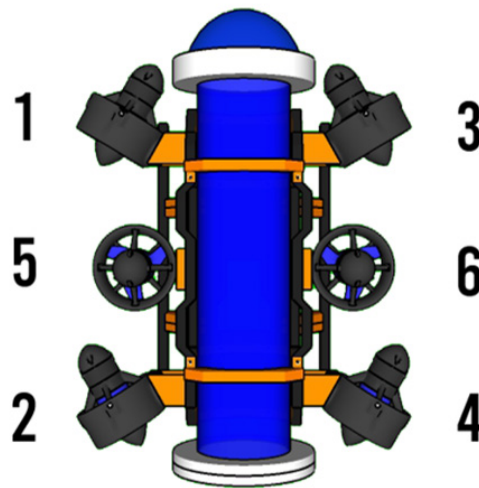

Figure 5. Thruster motor placement configuration on the N5 AUV.

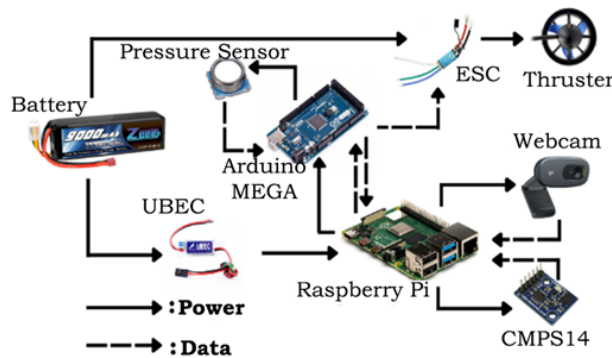

Figure 6. Power and data flow for electronics on the N5 AUV.

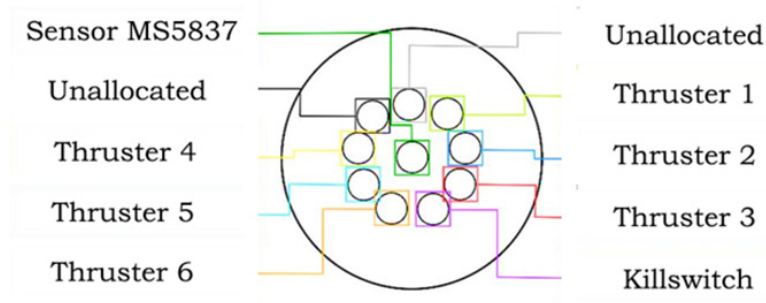

Figure 7. Penetrator installation plan on Nusantara 5 AUV.

Figure 7 illustrates the installation of penetrators on the rear cover of the N5. Several components, including the pressure sensor, kill switch, and thrusters, are positioned outside the pressure hull. The thrusters used in the Nusantara 5 AUV are Blue Robotics T200 thrusters (Figure 8). The T200 can operate within a voltage range of 7 to 20 V, with a minimum recommended operating voltage of 12 V. In the N5, a voltage of 14.8 V is applied to supply power to the T200.

The following diagram illustrates the layout of the electronics within the Nusantara 5 AUV. The N5's electronic components are mounted on an acrylic base measuring 43 cm in length and 7 cm in width. All electronic devices are powered by a 14.8V Li-Po battery connected to the terminal. The N5's battery has a capacity of 5200 mAh, while the N5 itself consumes 1,213.6 mA. Using the battery endurance formula outlined in the methodology, it is determined that the N5 can operate for approximately 4 hours and

17 minutes.

The electrical power from the battery is directed to UBEC, which converts the voltage from 14.8V to 5V. This 5V supply is used to power the Raspberry Pi, which then distributes power to the Arduino Mega and the webcam via USB cables. Through this setup, all electronic components within the AUV are interconnected and receive the necessary power for proper operation. The wiring layout and the placement of each component in the N5-AUV can be seen in Figure 9.

The battery supplies 14V electricity to the Electronic Speed Controller (ESC), which then distributes power to the T200 thrusters mounted outside the AUV's pressure hull.

Additionally, the control pins on the ESC are connected to the digital pins on the Arduino Mega, ensuring precise control. The pins used to operate the ESC include pins 2, 12, 6, and 7 for the horizontal thrusters and pins 4 and 5 for the vertical thrusters, as shown in Figure 10.

The CMPS14 sensor plays a crucial role in providing real-time compass data to the AUV. As shown in Figure 11, this sensor is connected to the Raspberry Pi using four wires: a 3.3 V power source, ground (GND), SDA, and SCL. Each of these wires is linked to the corresponding pins on the Raspberry Pi, enabling the CMPS14 sensor to function correctly and deliver directional information to the AUV.

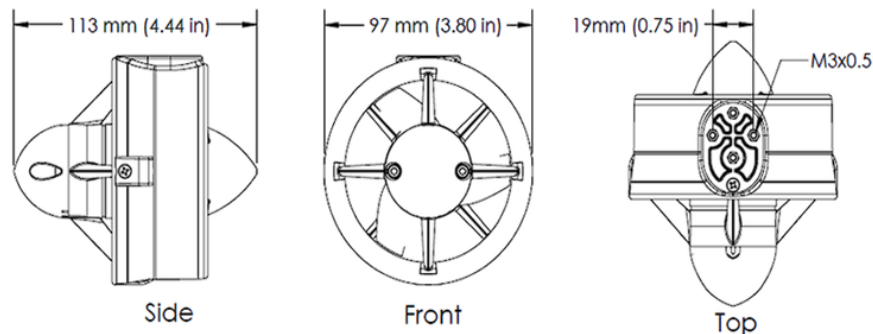

Figure 8. T200 motor size specifications as N5 AUV thruster (Blue Robotics 2021).

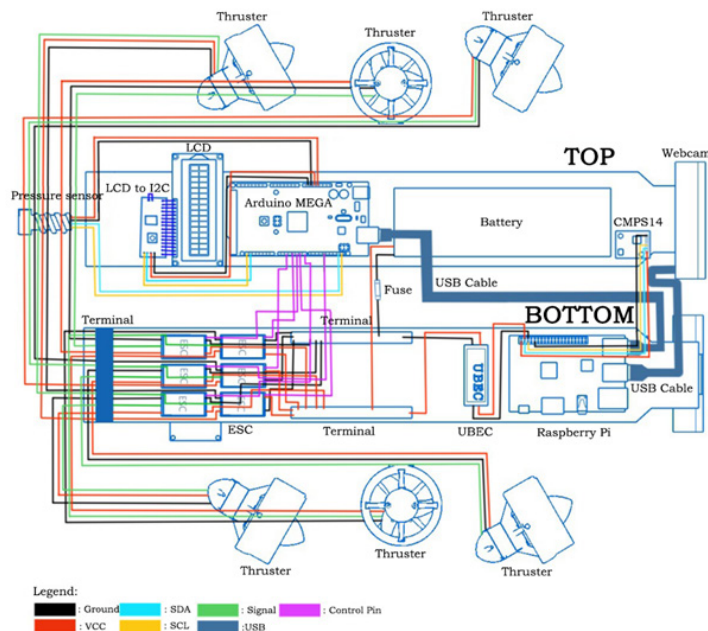

Figure 9. Wiring layout on the N5-AUV.

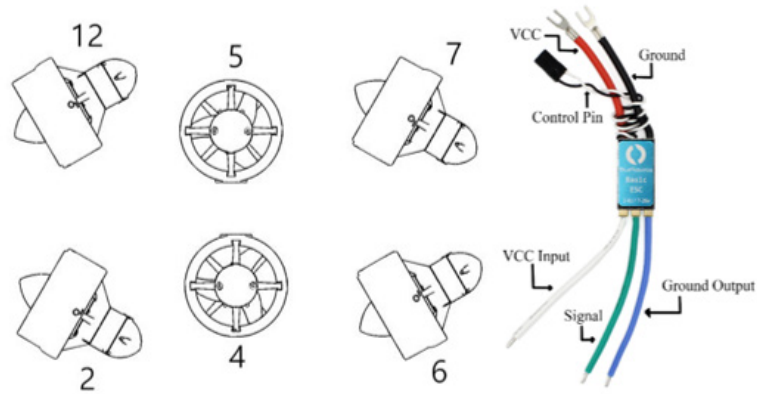

Figure 10. Blue Robotics ESC and pin number configuration.

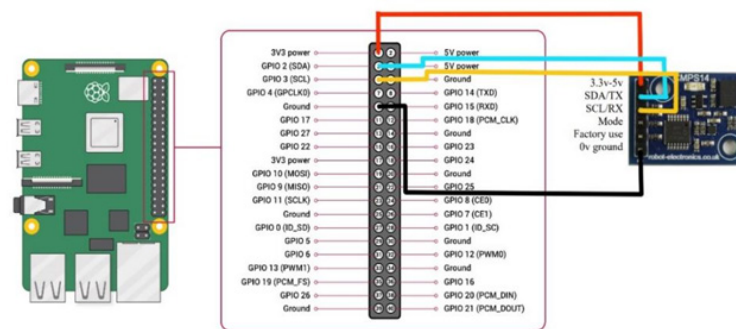

Figure 11. CMPS14 component cable connection to Raspberry Pi.

The depth sensor used in the AUV is the MS5837 sensor, which has a small dimension of approximately 3 mm. This sensor has been integrated into a custom-designed penetrator and sealed with Araldite to ensure water resistance. The penetrator is then securely attached to the AUV's pressure hull cover. The sensor's cables are connected to the designated Arduino pins, linking them to the system, as shown in Figure 12. With this configuration, the depth sensor is ready to operate effectively in underwater environments.

The I2C module is used to connect the LCD display to the Arduino Mega. In this configuration, the I2C module provides both power and communication pathways between the Arduino Mega and the LCD screen. This module allows the Arduino Mega to send data and commands to the LCD with high efficiency, enabling the display of important information as part of the AUV's user interface. The I2C module is connected to the Arduino Mega using four wires, each attached to the corresponding pins. The wiring connections can be seen in Figure 13.

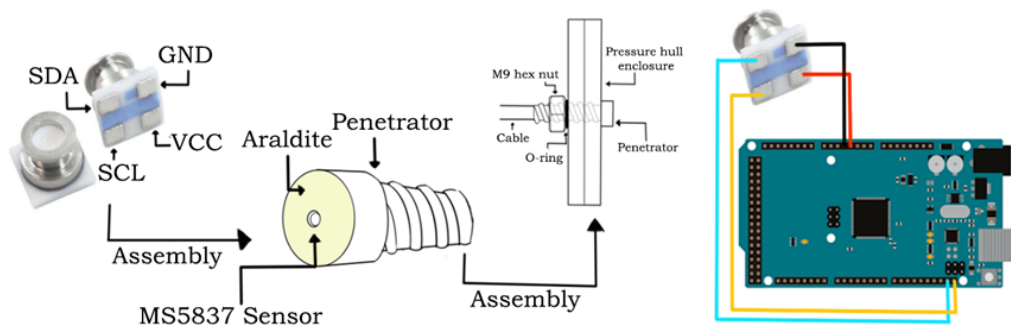

Figure 12. Installation of the MS5837 depth sensor on the N5 AUV cover.

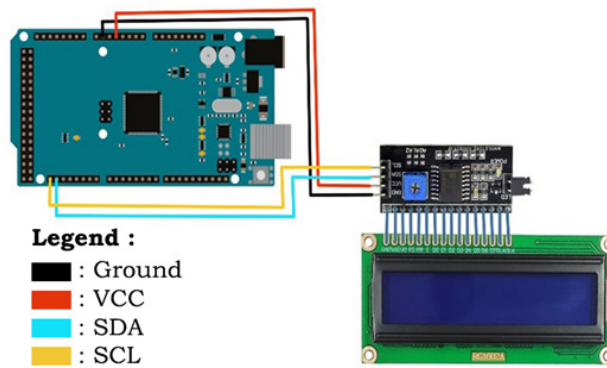

Figure 13. LCD connection to Arduino Mega.

### Software

The main program used in the AUV is written in Python. This program receives target direction information in the form of angle degrees using a real-time compass sensor. The program then communicates with the Arduino via a serial connection. The Arduino controls the thrusters based on the received commands, allowing the AUV to adjust its movement path and reach the targeted location.

The AUV movement program consists of several main stages, namely initialization, launch confirmation, and movement control within several loops, as shown in Figure 14. The program starts by importing the necessary modules, such as `Arduino_serial` for communication with Arduino, `CMPS12` for reading the AUV's direction, and `time` for time management. These modules enable the AUV to process movement commands efficiently. After importing the modules, the program initializes serial communication with the Arduino at a baud rate of 115200.

Once initialization is complete, the program waits for confirmation from the operator before executing any movement commands. This step ensures that the AUV is ready for operation and prevents unintended movement before deployment. When confirmation is received, the AUV enters the main loop, where movement commands are executed sequentially. The descent loop controls vertical movement based on depth sensor readings, ensuring the AUV reaches the desired depth. The forward loop adjusts direction and speed according to the compass sensor, allowing precise navigation. Finally, the stop loop ensures that all thrusters are turned off once the movement is complete, preventing unnecessary power consumption. The overall structure of the program can be seen

in Figure 15, which illustrates the execution flow from initialization to stopping the AUV.

### AUV movement testing

#### *Straight-Line movement testing*

As shown in Figure 15, when tested in a pool, the AUV performed a straight-line movement for 30 seconds, targeting a heading of 352 degrees. Data was recorded every 0.1 seconds, revealing that the average error during movement was approximately 2.8°. The maximum deviation reached 5°, while the minimum deviation was -7°. In contrast, during open-sea trials, the AUV moved in a straight line for 30 seconds, targeting a heading of 225 degrees. Data collection every 0.1 seconds indicated an average error of 5.4°, with the highest deviation reaching 15° and the lowest deviation at -6°. The results from the straight-line movement test highlight an interesting trend in open-sea conditions, where the AUV tends to drift beyond its target direction, particularly to the right of the intended heading. This deviation is primarily influenced by sea waves, whose average velocity near Semak Daun Island, close to the Hall of Sea Farming IPB, is approximately 0.45 m/s (Bramana *et al.* 2014), thereby affecting the AUV's movement. This finding aligns with Fauzi *et al.* (2021), which states that watercraft movements are influenced by wind, ocean waves, and tidal currents.

#### *Turning movement testing*

Turning movement trials were conducted with two different directional targets. As shown in Figure 16, the first target was 352°, while the second target was 77°. Each target was given 30 seconds to be reached, making the total AUV travel time 60

seconds. The transition from the first to the second target occurred at the 30th second, and the AUV required approximately 12.8 seconds to complete the turn. As a result, the AUV stabilized at the 42.8-second mark, resuming straight-line movement after turning.

Meanwhile, in the open-sea condition, the first target was 210°, and the second target was 300°. Again, each target was allocated 30 seconds, bringing the total travel time to 60 seconds. The direction change occurred at the 30th second, but the AUV required a longer time to stabilize in the sea, taking approximately 20 seconds. Consequently, the AUV only became stable at the 50-second mark before resuming straight movement.

It is important to note that the AUV

took longer to change direction in the sea than in the test pool. This is primarily due to ocean currents rather than water density. Sea currents exert lateral forces, altering the AUV's trajectory and requiring continuous compensation to maintain stability. While seawater density does affect drag forces, which impact power efficiency and speed, the dominant factor in turning maneuvers is the lateral force from sea currents and the thruster's thrust. During steady movement, thrust and drag forces are balanced, but during turning, directional control is more influenced by sea currents than by density. This observation aligns with Gonzales (2006), who stated that drag forces on AUVs depend on velocity and drag coefficients, while sea currents primarily cause trajectory deviations.

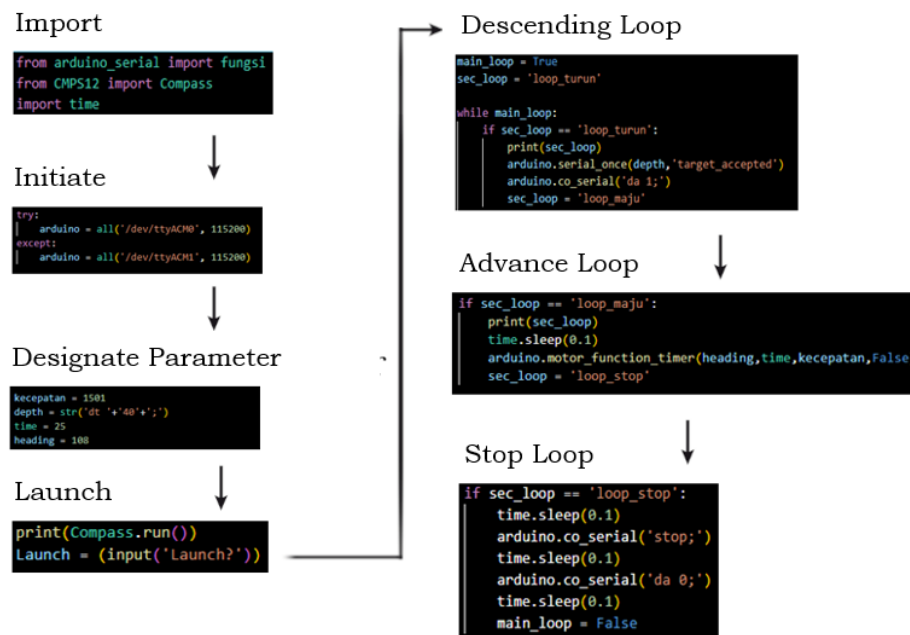

Figure 14. A snippet of the Nusantara 5 AUV program and its stages.

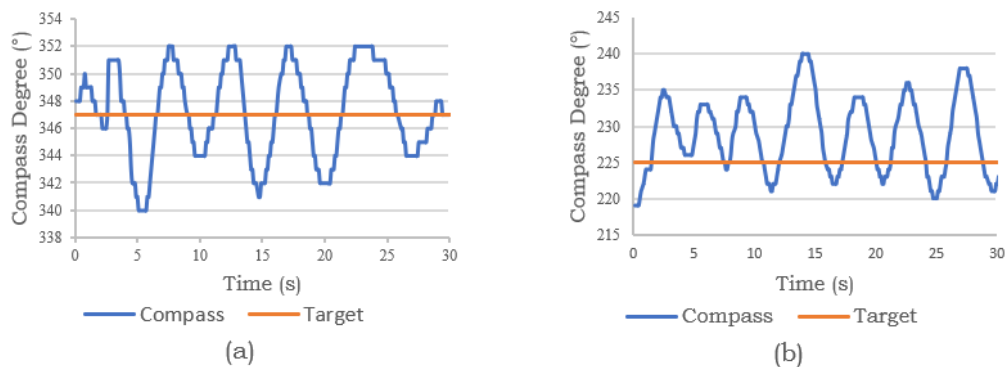

Figure 15. Straight motion graph, (a) Pool trial, (b) Sea trial.

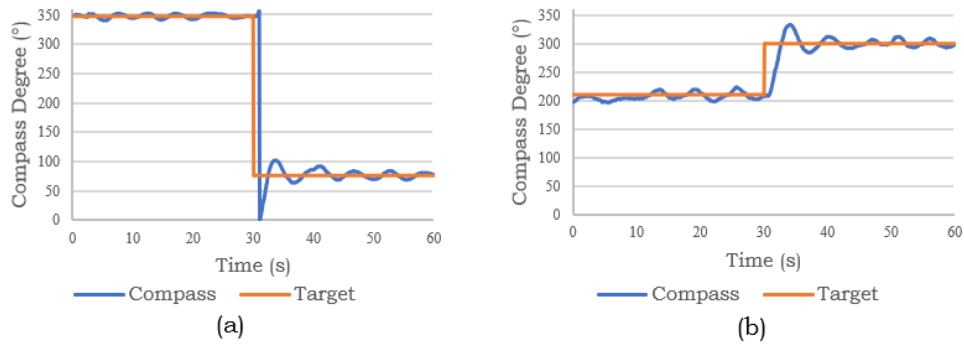

Figure 16. Turning motion graph, (a) Pool trial, (b) Sea trial.

### Gliding movement testing

Gliding movement is a critical maneuver in Autonomous Underwater Vehicle (AUV) operations, where the AUV must be capable of diving and moving forward without using its vertical thrusters to the surface. Initially, it was expected that the AUV would execute a perfect gliding motion, maintaining a straightforward movement while gradually ascending to the surface. However, practical implementation revealed an awkward reaction/movement. When the gliding motion program was executed, the AUV exhibited extreme vertical oscillations, rather than maintaining a smooth ascent. This behavior was observed both in the test pool and the sea, as shown in Figure 17 and Table 2. This instability in gliding is

identified as a weakness in the Nusantara 5 AUV. The cause of this issue may be related to the AUV's structural design, particularly the proximity of the center of buoyancy (CB) and center of gravity (CG). The CB is the point where the buoyant force acts upward, while the CG represents the average mass distribution of the vehicle. In underwater vehicle design, the distance between CB and CG, known as BG, plays a key role in determining stability, as illustrated in Figure 18. To achieve maximum stability, the BG distance should be increased by separating the CB and CG as much as possible (Moore *et al.* 2010). One way to achieve this is by lowering the vehicle's center of mass, particularly by repositioning heavier components such as the thrusters, to increase the separation from the CB.

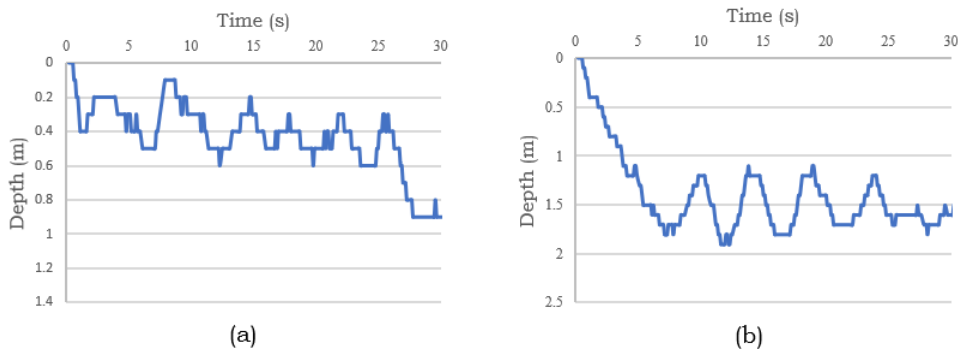

Figure 17. Gliding motion graph, (a) Pool trial, (b) Sea trial.

Table 2. AUV depth change over time in the test pool and at sea.

Time (s)	Average Depth (At Test Pool)	Average Depth (At Sea)
0-5	0.240426	0.676087
5-10	0.302273	1.541667
10-15	0.395238	0.7
15-20	0.4375	1.501053
20-25	0.477083	1.534043
25-30	0.697917	1.631915

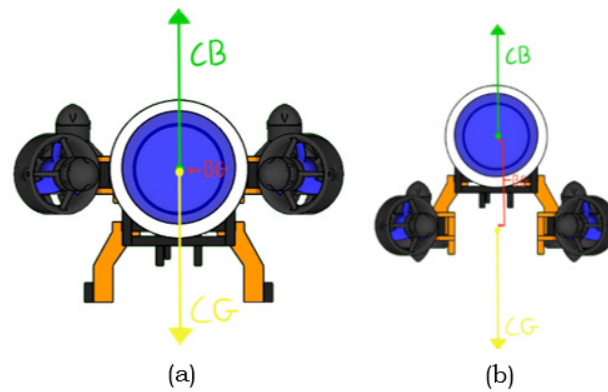

Figure 18. Distance between CB and CG, (a) Thruster on the side, (b) Thruster below.

## CONCLUSION

This research has successfully documented the design and development of the Nusantara 5 AUV. The AUV has also been successfully tested in both pool and sea environments, demonstrating its ability to execute various maneuvers. During straight-line movement, the AUV achieved an average error of  $2.8^\circ$  in the pool, while in the sea, the average error increased to  $5.4^\circ$  due to external factors such as waves and currents. For turning maneuvers, the AUV required 12.8 seconds to stabilize its direction in the pool, whereas, in the sea, it took 20 seconds due to the influence of water currents. However, the gliding motion remains imperfect in both pool and sea tests, as the AUV exhibits an unstable up-and-down movement pattern instead of maintaining a smooth glide. Further improvements in buoyancy and weight distribution are necessary to enhance gliding stability.

## REFERENCES

- Allotta B, Caiti A, Chisci L, Costanzi R, Di Corato F, Fantacci C, Fenucci D, Meli E, Ridolfi A. 2016. An Unscented Kalman Filter-Based Navigation Algorithm for Autonomous Underwater Vehicles. *Mechatronics*. 39(1): 185-195. DOI: <https://doi.org/10.1016/j.mechatronics.2016.05.007>.
- Blue Robotics. 2021. T200 Standard Drawing. <https://bluerobotics.com/store/thrusters/t100-t200-thrusters/t200-thruster-r2-rp/>. [14 Agustus 2024]
- Bramana A, Damar A, Kurnia R. 2014. Estimasi Daya Dukung Lingkungan Keramba Jaring Apung di Perairan Pulau Semak Daun Kepulauan Seribu, DKI Jakarta. *Jurnal Teknologi Perikanan dan Kelautan*. 5(2): 163-172. DOI: <https://doi.org/10.24319/jtpk.5.161-170>.
- Carreras M, Hernandez JD, Vidal E, Palomeras N, Ribas D, Ridao P. 2018. Sparus II AUV A Hovering Vehicle for Seabed Inspection. *IEEE Journal of Ocean Engineering*. 43(2): 344-355. DOI: <https://doi.org/10.1109/JOE.2018.2792278>.
- Desa E, Madhan R, Maurya P, Navelkar G, Mascarenhas A, Prabhudesai S, Afzulpurkar S, Bandodkar S. 2007. The Small Maya AUV: Initial Field Results. *International Ocean Systems*. 11(1): 1-9.
- Fauzi R, Jaya I, Iqbal M. 2021. Unmanned Surface Vehicle (USV) Performance Test in Bintan Island Waters. *The 4th International Conference Marine Sciences (ICMS 2021), 2021 August 24-25, Bogor, Indonesia*. IOP Conference Series: Earth and Environmental Science.
- Gonzalez LA. 2004. Design Modelling and Control of an Autonomous Underwater Vehicle [Thesis]. Perth (AU): University of Western Australia.
- Hakim A. 2014. Desain Bentuk Lambung ROV Sebagai Alat Inspeksi Visual Bawah Laut di Daerah Kolam Pelabuhan [Thesis]. Surabaya (ID): Institut Teknologi Sepuluh Nopember.
- Hiller T, Steingrimsson A, Melvin R. 2012. Expanding the Small AUV Mission Envelope; Longer, Deeper & More Accurate. *Symposium on Autonomous Underwater Vehicle Technology (AUV), 24-27 September*

- 2012, Southampton, UK. IEEE/OES Autonomous Underwater Vehicles (AUV).
- Hong EY, Soon HG, Chitre M. 2010. Depth Control of an Autonomous Underwater Vehicle, STARFISH. *OCEANS'10 IEEE Sydney, 24-27 May 2010, Sydney, Australia*. IEEE.
- Hyakudome T. 2011. Design of Autonomous Underwater Vehicle. *Journal of Advanced Robotic System*. 8(1): 122-130. DOI: <https://doi.org/10.5772/10536>.
- Jacobi M. 2015. Autonomous Inspection of Underwater Structures. *Robotics and Autonomous Systems*. 67(1): 80-86. DOI: <https://doi.org/10.1016/j.robot.2014.10.006>.
- Moore SW, Bohm H, Jensen V. 2010. Underwater Robotics Science, Design, and Fabrication (1st Ed). California (US): Marine Advanced Technology Education (MATE) Center.
- Ngatini, Nurhadi H. 2019. Estimasi Lintasan AUV 3 Dimensi (3D) dengan Ensemble Kalman Filter. *Jurnal Inovtek Polbeng Seri Informatika*. 4(1): 12-21. DOI: <https://doi.org/10.35314/isi.v4i1.774>.
- Ratnasari Y, Pandewo AF, Santoso SA, Anas DF, Lestari NA, Iqbal M, Jaya I. 2020. N3-AUV (Nusantara 3-Autonomous Underwater Vehicle): Design and Implementation for Underwater Exploration. *The 3rd International Conference on Marine Science (ICMS) 2019 "Towards Sustainable Marine Resources and Environment", 4 September 2019. Bogor, Indonesia*. IOP Conference Series: Earth and Environmental Science.
- Sahoo A, Dwivedy SK, Robi PS. 2019. Advancements in the Field of Autonomous Underwater Vehicles. *Ocean Engineering*. 181(1): 145-160. DOI: <https://doi.org/10.1016/j.oceaneng.2019.04.011>.
- Shome SN, Nandy S, Pal D, Das SK, Vadali SRK, Basu J, Ghosh S. 2012. Development of Modular Shallow Water AUV Issues and Trial Results. *Journal of The Institution of Engineers India: Series C*. 93(1): 217-228. DOI: <https://doi.org/10.1007/s40032-012-0026-0>.
- Sinaga AJ, Simanjuntak SMLH, Manurung CSP. 2020. Analisa Laju Korosi dan Kekerasan pada *Stainless Steel* 316 L dalam Larutan 10% NaCl dengan Variasi Waktu Perendaman. *SPROCKET: Journal of Mechanical Engineering*. 1(2): 92-99. DOI: <https://doi.org/10.36655/sprocket.v1i2.186>.
- Sugita IW, Dzaky MA. 2017. Analisis Geometri Peluru terhadap Nilai Drag Coefficient pada Kecepatan 304,8 m/s. *Jurnal Konversi Energi dan Manufaktur*. 4(2): 99-107. DOI: <https://doi.org/10.21009/JKEM.4.2.7>.
- Widiharto, Sukarso TB, Faisol A. 2022. Perkembangan Peran "Autonomous Underwater Vehicles" dalam Misi Pencarian dan Penyelamatan: Sebuah Kajian Operasional. *TechnoCOM*. 21(2): 311-319. DOI: <https://doi.org/10.33633/tc.v21i2.6113>.