

**AGGREGATION METHODS FOR ASSESING  
THE SUSTAINABILITY OF FOREST MANAGEMENT**  
*(Beberapa Metode Agregasi untuk Penilaian  
Kelestarian Pengelolaan Hutan)*

**RETNO KUSWANDARI<sup>1</sup>, M. ALI SHARIFI<sup>2</sup>, and M. BUCE SALEH<sup>3</sup>**

**ABSTRACT**

*Kelestarian pengelolaan hutan merupakan konsep yang samar dan kompleks, oleh karena itu tidak ada satupun alat ukur yang dapat mengukurnya secara jelas. Sertifikasi hutan digunakan sebagai instrumen untuk mengukur kelestarian pengelolaan hutan yang didasarkan atas kelestarian produksi, ekologi dan sosial. Kriteria dan Indikator (C & I) untuk kelestarian hutan alam produksi dalam sistem sertifikasi di Indonesia (Lembaga Ekolabel Indonesia) menggunakan Analytical Hierarchy Process (AHP) sebagai alat dalam proses pengambilan keputusannya.*

*AHP telah lama dikritisi, antara lain karena pendekatan kompensatori menggunakan model linier additive utilitas untuk mengintegrasikan -nilai baku. Riset ini bertujuan untuk menganalisa beberapa metoda agregasi nilai baku sebagai alternatif untuk menilai kelestarian pengelolaan hutan. Fuzzy AHP dan Rule Base (Fuzzy Reasoning Method) dipelajari sebagai metode untuk mengatasi kekurangan kemampuan AHP dalam menangani secara tepat peubah-peubah linguistik.*

*Data hasil proses penilaian sertifikasi Unit Pengelolaan Hutan Labanan, Kalimantan Timur, Indonesia digunakan untuk menilai kelestarian pengelolaan hutan dengan tiga metode tersebut. Hasil Fuzzy AHP dibanding dengan Normal AHP menunjukkan hasil yang lebih jelas dan sudah menampung ketidakpastian justifikasi ekspert yang tidak terdapat dalam Normal AHP. Metode Rule Base, yang sangat tergantung kepada pengetahuan dan pengalaman ekspertnya, memberikan hasil yang lebih berarti dan transparan dalam proses penilaian dibanding kedua metode lainnya, yaitu Normal AHP dan Fuzzy AHP*

**Keywords:** SFM assessment, forest certification, fuzzy decision making, AHP, Fuzzy AHP, Fuzzy Rule Base

**INTRODUCTION**

Sustainable Forest Management (SFM) is one of the important global issues. For a long time sustainability was almost only concerned with sustained yield of wood,

---

<sup>1</sup> Badan Planologi Kehutanan, Departemen Kehutanan RI

<sup>2</sup> International Institute for Geo-Information and Earth Observation (ITC), Enschede, the Netherlands

<sup>3</sup> Laboratorium Perencanaan Hutan, Fakultas Kehutanan-IPB Kampus Dramaga P.O. BOX 168 Bogor, e-mail: buce\_w@indo.net.id

nowadays the concept of SFM rests on three pillars, economic sustainability, ecological sustainability and social sustainability. Sustainability is difficult to define or measure because it is a vague and complex concept. There is a need for a practical tool to assess sustainability ((Phillis and Andriantiatsaholiniaina, 2001). Criteria and Indicators (C & I) is a tool that has been developed to support measuring SFM (Raison, Brown et al., 2001). In forest management context, C & I shares the aim to promote SFM with forest certification (Rametsteiner and Simula, 2003).

Forest certification is a procedure whereby an independent certifier gives a written assurance that a forest is managed in accordance with agreed ecological, economic and social criteria. It is a market instrument, which provides an incentive for SFM as it links producers and consumers in their responsible use of forest resources (GTZ, 2003). The principles to be fulfilled in the certification system are: (a) on a voluntary-based; (b) established in a multi-stakeholder process; (c) standards applied must meet the principles agreed internationally; (d) a transparent process; and (e) implemented by a third independent party. The total global area of certified forests is around 90 million ha, which represents only 2 percent of the world's total forest area. Most certified forests are located in a limited number of temperate countries, and not in tropical countries (FAO, 2002).

Sustainable Natural Production Forest Management (SNPFM) certification system has problems related to its input and processing. The existing system is based on a top down management model. It is found that C & I developed have little connection with the actual forest management practices. It also does not consider the new policies and the institutional requirements in assessment. The system includes a large set of C & I which are difficult to assess, and requires more time, resources, and a high expertise. The current attempts to measure and verify so many criteria, indicators, and verifiers (over 200) require large sets of information from the concessions. The proper acquisition, management and processing of such information is a complex process. In some cases, non existence, in others non-availability, accessibility and questionable reliability of the data and information, data capture, collection and processing, the time and cost that involved, has made the proper implementation of certification in accordance with these excessive number of hierarchically structured indicators very difficult to implement. The other problem is in integrating of the various data types, both spatial and non-spatial or quantitative and qualitative measurements.

Specific problem in the decision making process of the SNPFM certification is the use of the AHP approach in which linguistic variables "words", for instance Excellent, Good, Fair, Poor, Bad, are considered as numbers and mathematically integrated. According to Herwijnen (1999), using AHP method in MCDM process one has to be aware that the result obtained allows compensatory rules. This means that a bad performance of certain criterion can be compensated by a good performance of another criterion, because in the AHP the alternatives that are deficient with respect to one or more objectives can be compensated by their good performances with respect to other objectives. For example the area that is affected by forest fire can be compensated by having good Early Warning system and the stakeholder disagreement can be compensated by having a good boundary marking. The other problem is the final result which is a crisp number that still needs interpretation. Further more it does not consider the expert

confidence, attitude and knowledge and uncertainty in making judgment. To overcome the shortcoming in the existing method, it is necessary to employ a method, which can map the causal relationship between indicators and measuring the relative importance of each indicator in the achievement of the SFM.

Improving decisions about sustainability will require new approaches for integrating diverse value and information sources to address forest sustainability. Fuzzy logic theory provide possibilities for improvement, and simultaneously provide a simple but rigorous framework for rational decision making, and promising tools for SFM assessment (Mendoza and Prabhu, 2004). Jeganathan (2003) explored 4 different approaches: 2-tuple fuzzy linguistic approach; Fuzzy AHP; Fuzzy Reasoning approach; and Type-2 Fuzzy Reasoning approach, to find the alternatives for the current SNPFM system. This paper explores the suitability of fuzzy AHP and fuzzy reasoning for the sustainability assessment of production function as defined by LEI SNPFM.

## METHODS

### Decision Making Processes in Forest Certification

The Indonesian Ecolabeling Institute (LEI) certification system is based on the International Tropical Timber Organization (ITTO) guidelines for SFM. Components of the SNPFM certification system are standard, certification procedure, decision making process and requirement. All those system properties have been documented in a series of LEI Standards, Guidelines and LEI's Documents.

### Method of Decision Making on Sustainable Forest Management

Decision Making Process in SNPFM certification system considers 2 alternatives. The first alternative represents a situation with the "Passing performance", (minimum requirement in order to qualify for certification) set by the Expert-Pannel-2. The second alternative is the "Actual performance", which represent the actual performance value of the assessed FMU. The values P (Passing performance) & Q (Actual performance) is derived from weighted sum of individual performances over hierarchy of criteria using pairwise comparison of AHP. The resultant value of actual performance is compared with the resultant value of standard passing performance to derive the grades. The grade in SNPFM certification system is consist of 5 grades: Gold, Silver, Bronze, Cooper and Zinc. The value of a grade ranges between 0 and 1.

### Applied Methods

#### *Analytical Hierarchy Process (AHP)*

AHP works by assigning and developing priorities for alternatives and the criteria used to judge the alternatives. The criteria are usually measured on different scales that cannot be directly integrated. First, priorities are derived for the criteria in terms of their contribution to achieve the goal, then the actual contribution of each criteria/indicators are

derived and aggregated using linear weighted sum method. These priorities and their performance values are derived based on pairwise comparison judgment. The process of pairwise comparisons solves the problem of handling the different types of scales, by interpreting their significance to the users. Finally a weighting and adding process is used to obtain the overall performance of alternatives as to how they contribute to the goal. This weighting and adding parallels what one would have done arithmetically prior to the AHP to combine alternatives measured under several criteria having the uniform scale to obtain an overall result (Saaty, 1999). Weight sumes allows compensation between indicators and assumes crisp classes where in reality may not be relevant.

#### *Fuzzy AHP*

To improve the AHP process in handling the imprecision and subjectiveness in the pairwise comparison process, Buckley et al. have extended Saaty's AHP (Deng, 1999). They have applied triangular or trapezoidal fuzzy numbers to express the decision maker's assessments on alternatives with respect to each criterion. After the criteria are weighted, the overall utilities of alternatives, known as fuzzy utilities, are aggregated by fuzzy arithmetic using Simple Additive Weighting method. To prioritize the alternatives, their fuzzy utilities need to be compared and ranked. However this comparison process can be quite complex and may produce unreliable results. Thus to facilitate the pairwise comparison process and to avoid the complex and unreliable process of comparing utilities, Hepu Deng (1999) presents a multi attributes approach for effectively solving multi attributes problems involving qualitative data. Here triangular fuzzy numbers are used in the pairwise comparison process to express the decision maker's subjective assessments.

#### *Rule Base (Fuzzy Reasoning Method)*

Fuzzy set theory is a mathematical theory designed to model the vagueness or imprecision of human cognitive processes that pioneered by Zadeh (Lootsma, 1997). This theory is basically a theory of classes with unsharp boundaries. Any crisp theory can be fuzzified to the concept of a fuzzy set. The stimulus for the transition derives from the fact both the generality of a theory and its applicability to real world problems are enhanced by replacing the concept of a crisp set with a fuzzy set (Zadeh, 1994). Fuzzy logic is a scientific tool that permits simulation of the dynamics without a detailed mathematical description (Andriantiatsaholiniaina, Kouikoglou et al., 2004). In Fuzzy Reasoning method knowledge is represented by IF-THEN linguistic rules. Real values are transformed into linguistic values by an operation called fuzzification. Then simulation of the evolution of the overall system is represented by rules of the form of IF (antecedents) – THEN (consequent), where the implication operator THEN and the connectives AND among antecedents are fuzzy. The antecedent part of the rules contains some linguistic values of the decision variables, and the consequence part consists of a linguistic value of the objective function (Carlsson and Fuller, 2001). A final crisp value is obtained by defuzzification. Six step in Rule Base (Fuzzy Reasoning Method) is as follows: (1) define model input; (2) define linguistic variable (3) construct membership function; (4) fuzzification; (5) fuzzy inference and (6) defuzzification (Cornelissen, 2000).

The most important part in the Rule Base method is building the rules. The Cognitive Mapping technique (Mendoza and Prabhu, 2003) is employed to help building the rules (defining the order of importance of each indicators). The number of rules “R” depends on the number of linguistic variables values “L” and numbers of indicators “n” ( $R=L^n$ ). For SFM assessment using the Rule Base method, the normalized performances as derived from PCM are used as input and then aggregated by applying the rules from indicator level to the higher level till production principle. The rules used are represented by decision trees. The total number of decision trees from indicator level till production principle used in the current research is 21 for indicator level and 13 for their aggregation. Example of the decision tree used is shown in Figure 1. The decision tree reads from left to the right, as the following example:

- IF Indicator P1.5 is Excellent AND Indicator P1.6 is Good THEN Forest Management is Excellent.
- IF Indicator P1.5 is Poor THEN Forest Management is Poor.

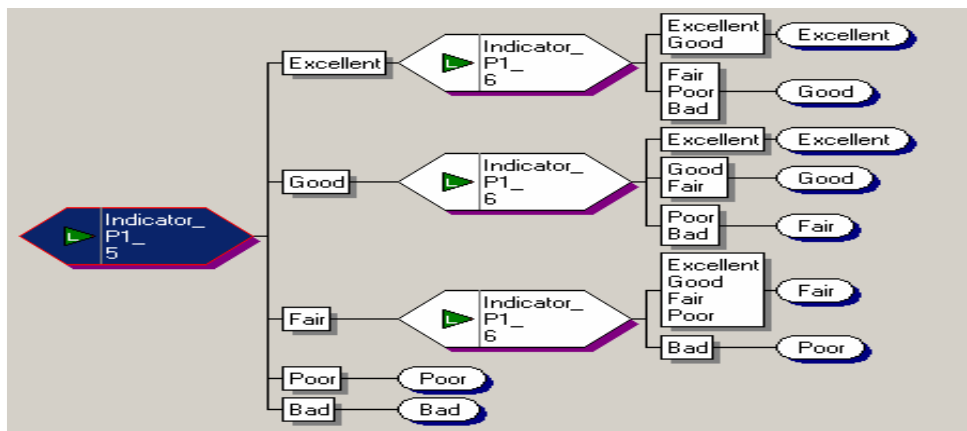

Figure 1. Decision tree for Forest Management Process in Forest Resources Sustainability Criteria.

Here the P1.5 is the most important, and P1.6, is the next level of importance in achieving the forest management.

To perform rule based assessment the Fuzzy Logic Toolbox in Matlab software with graphics user interface was used. The mathematical calculation has been carried out through the following steps:

Firstly, the membership functions for input variables and one output variable were selected. As an example the input variables are Indicator P1.5 and Indicator P1.6 and the output is Forest Management Process. The membership degree for linguistic class Bad is between 0 and 0.25, Poor is between 0 and 0.5, Fair is between 0.25 and 0.75, Good is between 0.5 and 1.0 and Excellent between 0.75 and 1.

Secondly, the decision rules for inferences in the form of “IF – THEN” arguments are developed. The number of rules depends on the number of inputs and number of linguistic classes of the inputs. For example Forest Management has 5 linguistic classes

and two inputs, then the number of the rules is  $5^2 = 25$ . But in practice we can reduce the result based on the expert knowledge and experience.

Next, the input values are introduced, and applying the set rules and the “AND” operator the output variables are calculated. Finally using the Central Gravity Defuzzification Rule (Phillis and Andriantiatsaholainaina, 2001) the defuzzification process is carried out and the final results are derived. As an example in the current research Indicator P1.5 has actual performance Fair or relative performance 0.3056 and P1.6 has actual performance Fair or crisp relative performance 0.4552 then the aggregation in Forest Management Practices become 0.316.

## RESULTS AND DISCUSSION

### Assessment Using the Normal AHP

The input for SFM assessment using the Normal AHP is the Pairwise Comparison Matrices (PCM) that is derived by the Expert Panel II who has carried out the decision-making process for certification of Labanan FMU. The calculation of the relative performance for all indicators is done individually for each indicator using the revised AHP-model which divides each relative value by the maximum value in the corresponding vector (Triantaphyllou and Lin, 1996; Belton and Gear, 1983). Based on this results the Labanan FMU received grade “Bronz”, meaning that the FMU passes the certification process with the actual performance (0.5241) which is higher than the passing performance (0.3805). Comparison of actual performance and passing performance for normal AHP can be seen in Figure 2. This shows that 10 indicators have actual performances higher than the passing performances, 11 indicators have actual performances same with the passing performance (no indicator has actual performance lower than the passing performance and FMU pass the certification for all aspects). The more important aspect in the certification process is to determine the grade of certification, which determines the number of visits and control “surveillance” that should be carried out in the coming 5 years after the certification. In this case Labanan FMU gets Bronze grade, which means 4 times surveillance within 5 year. Labanan FMU does not have either Poor or Bad indicators performances in Production Principle. Therefore it cannot show a clear example of the compensation of Bad performance in one indicator with Good performance in another indicator that can occurs in the assessment using AHP method.

### *Assessment Using Fuzzy AHP*

The input of SFM assessment using Fuzzy AHP is the crisp PCM that was used in the assessment using Normal AHP. The fuzziness is represented by a triangular membership. Fuzzification is done by using fuzzy extend analysis (Jeganathan, 2003). Then Alpha Cut function was applied in order to account for the uncertainty in the fuzzy range chosen. In this case it was assumed that the Expert-panel-II expresses his confidence about this ranges. The confidence value ranges between 0 and 1, from the least confidence to the most confidence. In the current research value 0.5 is used, meaning the Expert-

Pannel-II have the moderate confidence level. After applying Alpha Cut analysis it will get two values, Alpha Right (maximum range) and Alpha Left (minimum range) which need to be convert into a crisp value. It is done by applying Lamda function which represents the attitude of the decision maker. Different attitude of decision maker is maybe he is optimistic, moderate or pessimistic person. In the current research the moderate attitude is chosen. Finally the crisp values need to be normalized, because the elements of the PCM do not have the same scale.

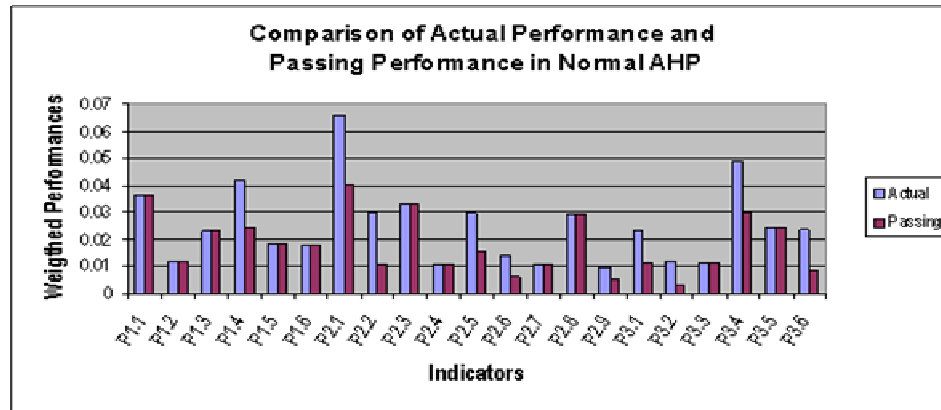

Figure 2. Comparison of Actual Performance and Passing Performance in the Normal AHP method

After obtaining the crisp value, the total utility is calculated and normalized between 0 – 1 to make it comparable to the other results. The assessment result using Fuzzy AHP also shows that the FMU certification grade “Bronze”, meaning the FMU passes the certification process (the actual performance 0.6414 is higher than the passing performance 0.5384). The comparison between the actual performance and the passing performance is shown in Figure 3.

The Fuzzy AHP has aim to clarify the result of the assessment using the Normal AHP by accommodating the uncertainty of experts judgment in building the PCM. In the current research moderate confidence level and attitude was applied. It obviously clarifies the result from the assessment using AHP that by accommodating the uncertainty that 10 indicators have actual performances more than the passing performances, 11 indicators have actual performances the same as the passing performance and no indicator has actual performance lower than the passing performance. Although if we compare each indicator individually, we can see that the relative performance is different, some indicators are more and others are less than in the Normal AHP performances. The conclusion is the same meaning Labanan FMU passes the certification with grade Bronze grade, so within 5 years period 4 times surveillance should be carried out.

Table 1. Normalisation of the Crisp Performance

| INDICATOR     | Lowest Range | Highest Range | Passing Performance | Actual Performance |
|---------------|--------------|---------------|---------------------|--------------------|
| P1.1          | 0.1432       | 1.2742        | 0.5519              | 0.5519             |
| P1.2          | 0.0878       | 0.7307        | 0.4136              | 0.4136             |
| P1.3          | 0.0915       | 0.6891        | 0.4125              | 0.4125             |
| P1.4          | 0.0609       | 0.4087        | 0.2793              | 0.4087             |
| P1.5          | 0.0733       | 0.5626        | 0.2463              | 0.2463             |
| P1.6          | 0.0277       | 0.2193        | 0.1389              | 0.1389             |
| P2.1          | 0.0100       | 0.0769        | 0.0541              | 0.0769             |
| P2.2          | 0.0503       | 0.4077        | 0.1502              | 0.3184             |
| P2.3          | 0.0614       | 0.5133        | 0.3885              | 0.3886             |
| P2.4          | 0.0520       | 0.1996        | 0.1329              | 0.1329             |
| P2.5          | 0.0571       | 0.5076        | 0.2199              | 0.3533             |
| P2.6          | 0.0232       | 0.1629        | 0.0977              | 0.1629             |
| P2.7          | 0.0410       | 0.3403        | 0.2077              | 0.2077             |
| P2.8          | 0.0363       | 0.1494        | 0.0923              | 0.0923             |
| P2.9          | 0.0058       | 0.0550        | 0.0017              | 0.0316             |
| P3.1          | 0.0061       | 0.0640        | 0.0476              | 0.0817             |
| P3.2          | 0.0026       | 0.0268        | 0.0104              | 0.0268             |
| P3.3          | 0.0036       | 0.0374        | 0.0288              | 0.0288             |
| P3.4          | 0.0445       | 0.2040        | 0.1012              | 0.1492             |
| P3.5          | 0.0281       | 0.2166        | 0.1559              | 0.1559             |
| P3.6          | 0.0259       | 0.2236        | 0.0752              | 0.1554             |
| Sum           | 0.9325       | 7.0697        | 3.8066              | 4.5343             |
| Normalization | 0.1319       | 1.0000        | 0.5384              | 0.6414             |

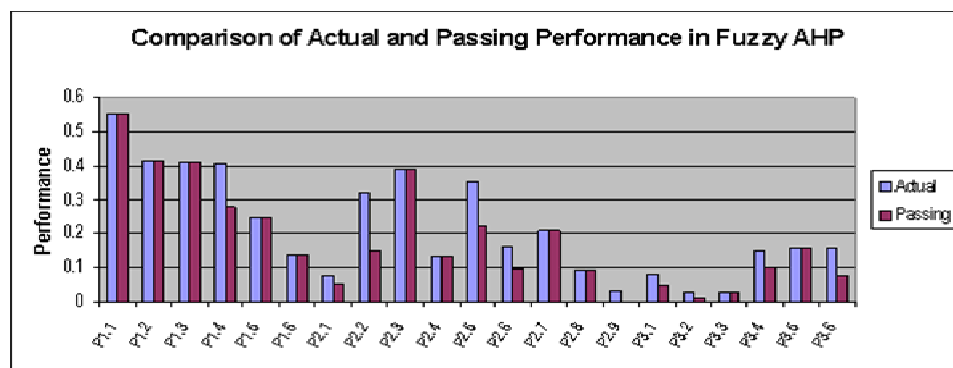

Figure 3. Comparison of Actual and Passing Performance in the Fuzzy AHP method



### *Rule Base Assessment*

Actually the assessment in the current research has been carried out in one run for actual performance and passing performance, by giving inputs in indicator level and the result is directly in principal level. Since all the rules in Decision Trees have already been entered in Fuzzy Logic Toolbox, it is only needed to write one mathematical script, which can facilitate the input values to follow the respective rules. To perform another assessment user can easily modify the input values. The result of assessment using Rule Base method shows that the FMU passes the certification with grade “Bronze”, as the actual performance (0.4760) is higher than the passing performance (0.2500) and as the consequence is that four times surveillance should be done within 5 years period

In level sub process “Production Management” for Passing Grades that contains six indicators, P2.2 (Fair with value 0.2382), P2.3 (Good with value 0.5767), P2.4 (Good with value 0.4990), P2.5 (Fair with value 0.2672), P2.6 (Fair with value 0.4396) and P2.7 (Good with 0.4232) will lead to value 0.2850 for “Production Management”, which give grade Poor to Fair (right part on membership function of “Poor” and left part on membership function of “Fair”). It is found that although three indicators have “Good” performance but it is not enough to bring up the “Production Management” performance become “Good”. It is also found that it has helped the expert to include different level of uncertainty for the value judgment and to understand its impact on the output. The experts knowledge and experiences is used to derive the fuzzy rules. By using this approach, diverse data, uncertainty in the input data, expert’s confidence and attitude are better handled than in other methods. Mathematical compensation in this method is avoided by using rule base along proper compositional operators in the inference mechanism.

### **Comparison of the Methods**

#### *Grade of Certification*

In the actual certification scheme for Labanan FMU, the Expert Panel II gave the final decision that the FMU pass the certification with Bronze grade, with the value 0.4388 for passing performance, 0.4543 for actual performance, 0.1598 for upper interval and 0.1870 for lower interval. Assessment in real certification process uses all of three principles, namely Production, Ecological and Social Principle, but in the current research only Production Principle is assessed. The assessment of SFM for Labanan FMU using three methods, the Normal AHP, the Fuzzy AHP and the Rule Base give the same conclusion of certification grade, namely Bronze. The grades of certification from the current research are the same with the real certification. Comparison of the range for each grade from the three methods can be seen in Table 2.

#### *Performance*

The result of SFM assessment using Normal AHP and Fuzzy AHP is not so much different. It is caused by the level of confidence and the attitude of the decision maker to select moderate confidence and attitude by select the value of 0.5 for both of Alpha cut function and Lamda function, which lead to select the medium value of the ranges. In this

case the medium value of triangular function has the similar value with the original value from crisp PCM.

Table 2. Comparison of ranges for the Certification Grade

| Grade of Certification    | Normal AHP    |               | Fuzzy AHP     |               | Rule Base (FRM) |               |
|---------------------------|---------------|---------------|---------------|---------------|-----------------|---------------|
|                           | Lower range   | Upper Range   | Lower range   | Upper Range   | Lower range     | Upper Range   |
| Gold                      | 0.7935        | 1.0000        | 0.8461        | 1.0000        | 0.7500          | 1.0000        |
| Silver                    | 0.5870        | 0.7925        | 0.6923        | 0.8451        | 0.5000          | 0.7490        |
| <b>Bronze</b>             | <b>0.3805</b> | <b>0.5860</b> | <b>0.5384</b> | <b>0.6913</b> | <b>0.2500</b>   | <b>0.4990</b> |
| Cooper                    | 0.1903        | 0.3795        | 0.2692        | 0.5374        | 0.1250          | 0.2490        |
| Zinc                      | 0.0000        | 0.1893        | 0.0000        | 0.2682        | 0.0000          | 0.1240        |
| <b>Actual Performance</b> | <b>0.5241</b> |               | <b>0.6414</b> |               | <b>0.4760</b>   |               |

It is found that for actual performance the difference of the result from Rule Base assessment with the Normal AHP is 0.0481 and with the Fuzzy AHP is 0.1654, then for passing performance the difference become large, namely 0.1305 with the Normal AHP and 0.2884 with the Fuzzy AHP. The large difference of the result from the Rule Base with the Normal AHP and the Fuzzy AHP are caused by:

- 1) Assessment using the Normal AHP and the Fuzzy AHP rely on the data and hierarchy from the current SNPFM certification system, but for the Rule Base assessment most relies on the rules that derived from experts' knowledge. There are different experts who carried out the actual certification for Labanan FMU and the experts who have been involved in the current research. So they will have different knowledge base for building the rules, different confidence level and attitude. The differences will influence the final result.
- 2) Although all assessments uses the same input, but the AHP and the Rule Base use different aggregation from indicator level to principal level. The AHP uses weighted summation method for aggregation, but the Rule Base method aggregation is based on tangible and meaning fule rules.

In the current SNPFM system the intensity scale for all indicators are not uniform. Some indicators have complete five intensity scales from Bad, Poor, Fair, Good and Excellent, but some indicators only have four even three-intensity scales. The standardization is done individually for each indicator.

The comparison of the Excellent, Good, Actual, Passing, Fair, Poor and Bad performances for the three different methods is as shown in Figure 4. It is found that the performance from the Normal AHP, the Fuzzy AHP and the Rule Base has the similar trend, but the performances from the Rule Base are the lowest.

The results of SFM assessment using the Normal AHP, the Fuzzy AHP and the Rule Base for Production Principle give the same degree of certification, namely Bronze. The result is the same with the result from the real certification grade for Labanan FMU which uses the whole hierarchy included Production Principle, Ecological Principle and Social Principle. The result from the SFM assessment using Normal AHP method is not surprising because the real certification also uses the same method. Using fuzzy PCM in the Fuzzy AHP means that the assessment has already accommodated the uncertainty

occurred in experts judgment, which is not accommodated in the Normal AHP. It means that the assessment should be more realistic, because it allows considering the confidence level and the attitude of the decision makers.

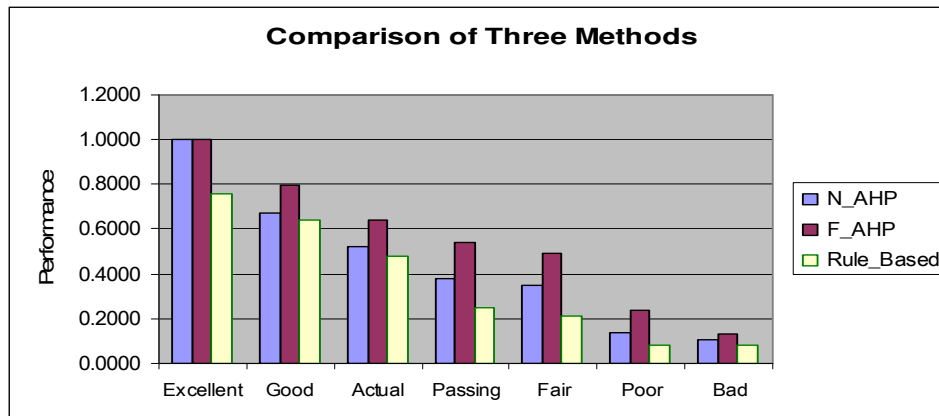

Figure 4. Comparison of the performances for the three methods

The Rule Base method tries to give in a more transparent way of SFM assessment by giving a set of rules that can be traceable from the indicator level until the principle level. The SFM assessment using the Rule Base method gives the same certification grade, but we should be aware with the result of passing performance that is perceived too low (0.2500) than the results by using the Normal AHP (0.3805) and the Fuzzy AHP (0.5384), also the actual performance is lower than in the Normal AHP (0.5241) and in the Fuzzy AHP (0.6414). On the other hand in the Normal AHP and the Fuzzy AHP method the weighted averaging or summation process tends to give extreme evaluations or exaggerate the real conditions (Ducey and Larson, 1999), so it is possible lead to overestimation in assessment.

It has already been explained in the former discussion that the aggregation methods used in the Normal AHP and the Fuzzy AHP is weighted summation methods, but in the Rule Base method the aggregation from the rules itself. The Rule Base method uses logical approach so it is perceived more subjective than the others methods. The proper rules are needed to represent the good decision and for that we need a deep understanding of the meaning and the role of each indicators and their interactions in SFM in order to be able to build proper rules. Another important note is that the threshold values play important role in the assessment, but the assessment itself is not an exact exercise. Therefore in actual assessment the threshold values can be modified and simulated in order to gain meaningful insights about the assessment (Mendoza and Prabhu, 2004).

#### *Strengths and Weaknesses*

After examining the results of SFM assessment using the different aggregation methods, the Normal AHP, the Fuzzy AHP and the Rule Base method, then the strengths and weaknesses of these three methods can be compared in the Table 3. The comparison

will be based on three aspects, namely logical and operational aspect, user aspect and implementation aspect.

Table 3. Strengths and weaknesses of the three methods

| Aspect                  |   | Normal AHP  | Fuzzy AHP  | Rule Base   |
|-------------------------|---|---|--|---|
| Logical and operational | S | Simple<br>Easy to understand  | Accommodates uncertainty   | More accommodates uncertainty<br>No compensation<br>Consider interaction across certain hierarchy<br>Based on a logical approach<br>Give more insight<br>More traceable (transparent) |
|                         | W | Compensation<br>Does not consider interaction across certain hierarchy<br>Based on a mathematical approach<br>Does not accommodate uncertainty. | Compensation<br>Does not consider interaction across certain hierarchy<br>Based on a mathematical approach | Needs more effort to build rules and to select the proper membership function.  |
| User                    | S | Most popular<br>Familiar for forest certification practitioners and decision makers.  | Not so much different with the current method  | -   |
|                         | W | -   | Need higher expertise user   | Perceived more subjective and more complex.   |
| Implementations         | S | The current method applied  | Extension of the current method applied  | If DSS available become friendly user   |
|                         | W | -   | Need more effort   | Need to convince the decision makers.   |

S: strengths W: weaknesses

## CONCLUSION

By examining the strengths and weaknesses of each different aggregation method in Table 3, it can be concluded as follows:

- 1) The existing AHP based assessment systems of certifications is subject to some problems, e.g., the compensatory nature of the method and the difficulty of assessment. The decision making process is based on the heavy judgments of experts at different levels. For good assessment requires specialized and high quality experts with a good

understanding of the method, which in practise hard to find, especially in large numbers. That limits the good application of the methodology.

- 2) The Rule Based method, which is based on expert rules, is the better method for SFM assessment than the Normal AHP and the Fuzzy AHP, which is based on a mathematical calculation. It gives more insight and meaning and is more transparent way of assessment. Although it is perceived more subjective than the Normal AHP and the Fuzzy AHP, the subjectiveness can be minimized by building fix rules until indicator level. The rules should be derived from experts' knowledge and the experts involved should have a deep understanding of the SNPFM certification system as well as experienced in the field. The rules can be applicable to any area, with some modification on the "Passing Performance" as the threshold of SFM assessment to accommodate the local adaptabilities through typology of the assessed FMU. Since rules are fixed they can be built in a decision support system with a user-friendly interfaces to facilitate the implementation of the process.
- 3) The application of fuzzy rule base in environmental management like in SFM assessment is still in the explorative phase. It needs more time to introduce the new method to the decision maker and it still remains difficult to operationalize since this method is quite new and the rules are not yet well established.
- 4) For implementation aspect, the simpler the method the more understandable it is to the user and easier to be implemented, but the result still cannot represent a good evaluation. Method that gives more insight meaning to SFM assessment needs more effort to built and implemented. So a trade off always occurs when we decide to implement one of the three different aggregation methods.

## REFERENCES

- Andriantiatsaholiniaina, L. A., V. S. Kouikoglou, et al., 2004. Evaluating strategies for sustainable development: fuzzy logic reasoning and sensitivity analysis. *Ecological Economics*, **48**(2): 149-172.
- Belton, V. and Gear, T., 1983. On a short-coming of Saaty's method of analytic hierarchies. *Omega*, **11**(3): 228-230.
- Carlsson, C. and R. Fuller (2001). Optimization under fuzzy if-then rules. *Fuzzy Sets and Systems*, **119**(1): 111-120.
- Cornelissen, A. G., J. v. d. Berg, et al., 2000. Assessment of Sustainable Development: A Novel Approach Using Fuzzy Set Theory. URL: <http://www.eur.nl/WEBDOC/doc/erim/erimrs20000622134831.pdf>. 25th June 2003.
- Deng, H., 1999. Multicriteria analysis with fuzzy pairwise comparison. *International Journal of Approximate Reasoning*, **21**(3): 215-231.
- Ducey, M. J. and B. C. Larson, 1999. A fuzzy set approach to the problem of sustainability. *Forest Ecology and Management*, **115**(1): 29-40.
- FAO, 2002. State of The World's Forests 2001. Rome, Food and Agriculture Organization of the United Nations: 18 - 20.
- GTZ, 2003. Forest Certification. URL: <http://www.gtz.de>. 30 October 2003.

- Jeganathan, C., 2003. Development of Fuzzy Logic Architecture to Assess the Sustainability of the Forest Management. MSc. Thesis. Enschede, ITC: 126.
- LEI, 2000. Joint Certification Program (JCP) Between LEI - FSC. Ecolabel News, **1**: 1 - 4.
- LEI, 2000. LEI Guideline 99 Series : Sustainable Production Forest Management (SPFM) Certification System. Bogor, Indonesia. Bogor, Indonesia, Lembaga Ekolabel Indonesia (The Indonesian Ecolabelling Institute).
- Lootsma, F. A., 1997. Fuzzy Logic for Planning and Decision Making. Dordrecht, Kluwer Academic Publisher.
- Mendoza, G. A. and R. Prabhu, 2003. Qualitative multi-criteria approaches to assessing indicators of sustainable forest resource management. *Forest Ecology and Management*, **174**(1-3): 329-343.
- Mendoza, G. A. and R. Prabhu, 2004. Fuzzy methods for assessing criteria and indicators of sustainable forest management. *Ecological Indicators* In Press, Corrected Proof.
- Phillis, Y. A. and L. A. Andriantiatsaholainaina, 2001. Sustainability: an ill-defined concept and its assessment using fuzzy logic. *Ecological Economics*, **37**(3): 435-456.
- Raison, R. J., A. G. Brown, et al., 2001. Application of Criteria and Indicator to Support Sustainable Forest Management: Some Key Issues. *Criteria and Indicators for Sustainable Forest Management*. D. W. Flinn. Wallingford, CABI in association with The International Union of Forestry and Research Organizations (IUFRO): 462.
- Rametsteiner, E. and M. Simula, 2003. Forest certification--an instrument to promote sustainable forest management? *Journal of Environmental Management*, **67**(1): 87-98.
- Saaty, T. L., 1999. The Seven Pillars of the Analytic Hierarchy Process. ISAHP, Kobe.
- Triantaphyllou, E. and C.-T. Lin, 1996. Development and Evaluation of Five Fuzzy Multiattribute Decision Making Methods. *International Journal of Approximate Reasoning*, **14**: 281-310.
- Zadeh, L. A., 1994. Fuzzy Logic, neural Network, and Soft Computing. *Communications of the ACM*, **37** (33): 77 - 84.